

Aksa Power Generation has been producing industrial generator sets with an innovative compact design and excellence in quality for over 30 years. Aksa has been providing reliable power through three main production plants and over 15 branch offices worldwide.

Alternator (125 °C Rise)	Voltage	Ph	Pf	Hz	Stand-by Ratings		Prime Ratings	
					kW/kVA	Amp	kW/kVA	Amp
UCI274G Winding #311	480/277V	3	0.8	60	178/222	268	161/201	242
	440/254V	3	0.8	60	178/222	292	161/201	264
	240/139V	3	0.8	60	178/222	535	161/201	484
	240/120V	3	0.8	60	178/222	535	161/201	484
UCI274G Winding #06	208/120V	3	0.8	60	178/222	618	161/201	559
	240/120V	1	1	60	165/165	687	150/150	625



Rating Definition

Stand-by Power (Maximum): Power available at variable load in the event of main power network failure. No over load is permitted.

Prime Power: Power available at variable load in lieu of a main power network. Overload of 10% is permitted for 1 hour in every 12 hours of operation.

The above ratings represent the engine performance capabilities to conditions specified in accordance with ISO 8528/5 & ISO3046.

Derating may be required for conditions outside of the test conditions.

Codes & Standards

U.S.EPA

EPA Certified Tier3 for Emergency Stationary Applications.



The Generator set is **UL2200 listed**. Dual wall **UL142** listed fuel tanks are also available.



The Generator set is designed and manufactured in a facility certified to **ISO9001:2008** standards.



The Generator set is designed and manufactured in a facility certified to **ISO14001:2004** standards.

NFPA

The Generator meets **NFPA110**, Level 1 when equipped with the necessary accessories and installed per NFPA standards.

Standard Features

Aksa Power Generation provides **single source responsibility** for the generator set & accessories.

The generator set, with its components, are **prototype tested** and **production tested** according to the UL test program.

Perkins heavy duty four cycle industrial diesel engine delivers low emission, reliable power, fuel efficiency and fast response to load changes.

Newage Stamford industrial generators meet the requirements of BS EN 60034 and the relevant sections of other international standards such as BS5000, VDE0530, NEMA MG1-32, IEC34, CSA C22.2-100, AS1359.

Non-proprietary NFPA110 compliant control system provides total gen-set system integrated control, protections, metering, automatic starting/stopping with options of remote control, remote display or remote annunciation.

Heavy duty base frame with integral pad **vibration isolators** eliminates the need for under unit spring vibration isolators.

Engine Data

Manufacturer	Perkins
Model	1106D-E66TAG4
Cylinders	6, in-line
Max. power @ rated rpm; kW _m (BHP)	204 (274)
Brake mean effective pressure; kPa	2065
Aspiration & Cooling	Turbo charged and air charge cooled
Total displacement; L (in ³)	6.6 (402.8)
Bore; in. (mm)	4.13 (105)
Stroke; in. (mm)	5.0 (127)
Compression ratio	16.2:1
Governor type	ECM, Isochronous 0.25
Rated rpm	1800
Rotation	Clockwise

Engine Electrical System

Charging alternator	12V, Negative Ground
Alternator rating; (amp)	100
Starter motor power; (kW)	5.0
Starter motor rated voltage; (dc)	12
Battery quantity x rating & CCA	1 x 80Ah, 622

Fuel System

Injector	Electronic
Fuel pump	CR200
Fuel supply connection size	3/8" NPT
Fuel return connection size	3/8" NPT
Max. fuel lift; m (ft)	3 (9.84)
Fuel prime pump	Manual
Max. fuel flow; L/min (gal/min)	1.5 (0.4)
Fuel temp at engine fuel pump inlet; °C (°F)	80 (176)
Fuel filter & water separator	Available

Fuel Consumption (gph)

110% Load	13.7
100% Load	12.8
75% Load	9.8
50% Load	6.9

Exhaust System

Exhaust gas flow; (m ³ /min)	35.5
Max. back pressure; (kPa)	15
Max. exhaust gas temp in manifold; (°C)	537
Exhaust outlet size; (mm)	90

Cooling System

Radiator ambient temp; °C (°F)	50 (122)
Coolant capacity; L (gal)	21 (5.5)
Coolant pump drive	Gear
Coolant pump flow; L/min	215
Thermostat operation range; °C	82-95
Cooling fan type	Pusher
Cooling fan air flow; m ³ /min	313.8
Combustion air flow; m ³ /min	13.4
Engine coolant flow; L/min (gal/min)	216 (57)
Heat rejection to coolant and oil; kWt	93.5
Heat rejection to ambient; kWt	16.2
Air filter	Paper element

Lubrication System

Oil capacity; L (gal)	16.5 (4.36)
Oil cooler	Water cooled
Oil filter	Spin on, replaceable
Oil temp (continuous operation); °C	125
Oil consumption @ full load (as a % of fuel consumption)	<0.1

Alternator Data

Manufacturer	Stamford
Model	UCI274G
Design	4 Pole, drip proof rotating field
Exciter type	Brushless, self excited P.M.G. option is available
Stator	2/3 winding pitch
Rotor	Single bearing, flexible disc
Leads	
Winding #311	12
Winding #06	4
Voltage regulator	Solid state, Volts/Hz
Voltage regulation	
Self excited	1%
PMG	0.5%
Insulation	Class H
Protection	IP23
Temp. rise @ 40°C ambient	125°C Prime 150°C Standby
Alternator Cooling	Direct drive centrifugal blower
Waveform distortion	No load < 1.5% Non-distorting balanced linear load < 5%
Max. over-speed; rev/min	2250
Telephone influence factor (TIF)	<50
Telephone harmonic factor (THF)	<2%
Sustained short circuit current 10sec; (amp)	
Winding #311 – Star	970
Winding #311 – Parallel Star	1840
Winding #06	2730

Control System



DSE7320 is an advanced control system, suitable for a wide variety of single, diesel or gas, gen-set applications. Monitoring and an extensive number of engine parameters, the module displays warnings, shutdowns and engine status information on the back lit LCD screen, illuminated LEDs, remote PC and via SMS text alerts (with external modem).

- UL recognized, NFPA110 Level 1 compatible
- LCD text display, key menu navigation and front panel editing
- Off/Manual/Auto model switch
- Two wire starting/stopping in Auto mode
- Engine exerciser
- IP65 front panel rating with supplied sealing gasket
- Configurable 9 inputs, 8 outputs with expansion capability
- Real time clock provides accurate event logging
- Fully configurable via DSE Configuration Suite PC software
- Remote SCADA monitoring and BMS integration features
- License free PC software

Protections

- Gen. Voltage - under/over
- Gen. Frequency - under/over
- Engine Speed - under/over
- Engine Oil pressure - low
- Engine Temp. - low/high
- Battery Voltage - low/high
- Weak battery
- Fail to start/stop
- Charge fail
- Over current & load(kW/kVA_r)
- Unbalanced load
- Independent Earth Fault
- Reverse Power
- Fuel level - low/high (optional)
- Loss of speed signal

Instruments

- Gen. Voltage (L-L/L-N)
- Gen Frequency
- Engine Speed
- Oil Pressure
- Water Temperature
- Battery Voltage
- Run time
- Engine maintenance due
- Phase sequence
- Pwr. monitoring (kWh / kVAh / kVA_{rh})
- Power (kW/kVA/kVA_r)
- Power factor
- Gen. Current (L1-L2-L3)
- Earth current

Locked rotor kVA (skVA) @30% voltage dip

	Self Excited	PMG Excited
480/277V - 3ph	640	735
208/120V - 3ph	485	580
240/120V - 1ph	395	510

Standard Features & Accessories

- UL2200 Listing
- Sound Attenuated Steel Enclosure
- 150mph Wind Rating
- Heavy Duty Steel Base-frame
- Anti-vibration pads
- Residential Grade Silencer Inside Enclosure
- Flex Fuel Lines
- Oil Drain Valve & Extension
- Emergency Stop Switch
- Battery, Battery Rack & Cables
- Battery Charger (4 Amp)
- Main Line CB (80% rated)
- Jacket Water Heater (1000W)
- Operations Manual
- 2 Years / 2000hours Limited Warranty

Optional Accessories

- Upsized Alternator
- PMG Excitation
- Alternator Anti-condensation Heater
- Manual Speed Adjust
- Sub Base Fuel Tank (UL142 / UL2085)
- Low Fuel & Fuel Leak Alarms
- Fuel Level Monitoring on Controller & High Fuel Alarm
- Spring Type Anti-vibration pads
- Critical Grade Silencer
- Fuel Line Check Valve
- Oil Temperature Gauge
- Remote Emergency Stop Switch
- Battery Restraint
- Battery Charger 10/20Amp per NFPA110
- Main Line CB (100% rated)
- Main Line CB Shunt Trip
- Remote Serial Display Panel
- Remote Annunciation Panel (8/16/24 lights)
- 5 Years / 2000hours Limited Warranty

Dimensions & Weight & Sound Level

Gen-set Without Fuel Tank

	Open Type	Enclosed Type
L (in.)	90	129
W (in.)	43	46
H (in.)	62	70
Weight (lb)	4361	5066
Sound Level (dBA@23ft)		78

Fuel Tank – UL142

	24h(310gal)	48h(615gal)	72h(925gal)
L (in.)	148	148	210
W (in.)	43.5	43.5	43.5
H (in.)	19	36	36
Weight (lb)	1575	2250	3100

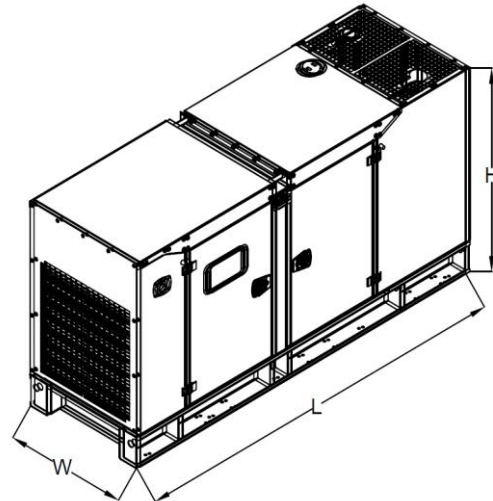

*Manufacturer reserves the right to make changes in model, technical specifications, color, equipment and accessories without prior notice.



AKSA POWER GENERATION USA LLC
 371 Exchange Street, West Monroe, LA 71292
 Tel: 318.855.8377
 Fax: 318.855.8381
 E-mail: sales@aksausa.com

Aksa Power Generation USA is a member of



KAZANCI HOLDING